

Instructions for Installing ProMelt Contactor Panels

For ProMelt CP-50, CP-100, CP-200, and CP-200EX Panels

The CP-50, CP-100, CP-200, and CP-200EX are turn-key panels for activating a ProMelt snow melting system when used in conjunction with the ProMelt series of controls. They allow simple connection from the circuit breaker panel and have a manual override timer and heating indicator. The CP-200EX is an "extension" panel that connects to one of the other panels and allows additional circuits to be controlled.

Installation

General

These panels must be installed in accordance with local building codes, the National Electrical Code, or Canadian Electrical Code by qualified persons.

Disconnect power from all circuits prior to making any connections.

Do not energize circuits until all connections are made and all ProMelt mats/cables are fully installed and covered as required.

Read and follow the installation instructions for both the ProMelt snowmelt mat/cable and the ProMelt sensor for additional information.

Mount the panel indoors on a wall or equivalent. Do not place in a confined air space where heat is not able to escape, such as a small closet.

Properly secure the panel to the wall using the mounting holes provided.

Wire the panel according to the provided schematics.

A GFCI type circuit breaker **must be used** to protect each ProMelt circuit. Size circuits for 125% of the load.

This panel must be bonded to ground, as well as all conduit, junction boxes and other associated items per local code.

Models CP-50, CP-100, and CP-200

- Provide 120, 208, 240, or 277 VAC circuits to the panel contactor(s) **L1 and L2** terminals as required by the rating of the ProMelt snow melting mats/cables connected to this circuit. As shown in the wiring schematics, the panel draws internal power from Contactor **C1** terminals, so make sure power is supplied to this contactor.
- For 120, 208, and 240 VAC systems, connect the transformer **COM** lead wire to contactor **C1** terminal **L1**. Connect the transformer lead wire matching the contactor voltage supplied to **C1** terminal **L2**.

⚠ CAUTION: Incorrect voltage supplied to the transformer may cause damage, fire, or shock.

- For 277 VAC systems, a separate 120 VAC circuit will need to be supplied to the transformer 120 VAC and **COM** lead wires directly. This may be a standard 15 A or 20 A circuit.

Control Descriptions		
Control	No. Contactors	Max. Amp Load
Contactors Pro CP-50	1	50
Contactors Pro CP-100	2	100
Contactors Pro CP-200	4	200
Contactors Pro CP-200EX	4	200



The ProMelt Contactor Control Panel is available in four configurations. CP-50 (single contactor), CP-100 (dual contactors), CP-200 (quad contactors), and CP-200EX (extension module).

- Use outdoor rated 4-conductor cable to make connections between this panel and the sensor selected. See the wiring schematic and instructions provided with the sensor for proper connections. Connect to terminal block terminals **S1, S2, and Y2** and also to the grounding bar. This will be a Class 2, 24 VAC circuit.
- Make wire connection between the contactor **T1 and T2** terminals and the ProMelt mats/cables.

Models CP-200EX

This panel is designed to be used in conjunction with a CP-50, CP-100, or a CP-200 Control Panel. Follow the steps below for proper operation:

- Provide 120, 208, 240, or 277 VAC circuits to the panel contactor(s) **L1 and L2** terminals as required by the rating of the ProMelt snow melting mats/cables connected to this circuit.
- Use a 2-conductor cable to make connections between terminals **R1 and R2** in this panel and terminals **R1 and R2** in the main CP-50, CP-100, or CP-200 panel. This will be a Class 2, 24 VAC circuit.
- Make wire connection between the contactor **T1 and T2** terminals and the ProMelt mats/cables.

Transformer Colors	
Primary Voltage	Lead Colors
120 Volts	Black & White
208 Volts	Black & Red
240 Volts	Black & Orange

Operation

Once all wiring connections have been completed, the sensor and ProMelt mats/cables have been fully installed, and any inspections made as required per local code, energize the circuit breaker(s) supplying the panel.

Automatic Operation

This is the recommended mode of operation. The sensor will activate the panel, energize the connected ProMelt mats/cables indicated by the "Heating On" light on the front of the panel.

Manual Operation

This mode is not recommended except for briefly testing the system or temporarily overriding the sensor control to complete melting or drying of a snow melted area. If this is required often to help complete the snow melting of an area, it is recommended to adjust the sensor control or consult your system designers for possible improved automatic sensing and control.

Turn the Timer to the desired time. This overrides the sensor and activates the panel, energizing the connected ProMelt mats/cables, shown by the "Heating On" light.

Do not manually energize the ProMelt mats/cables with outdoor temperatures above 50°F except for a brief test up to 10 minutes in duration. Damage to the mats/cables or slab/surface materials may result.

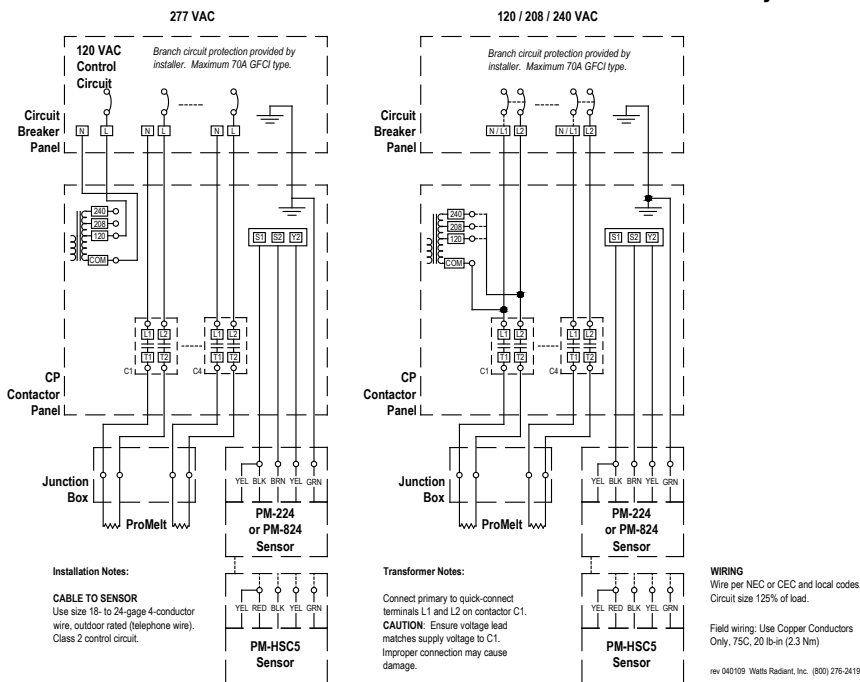

CP series of controls can be used directly with any ProMelt cable or mat system. Power is connected directly to each contactor in the control.

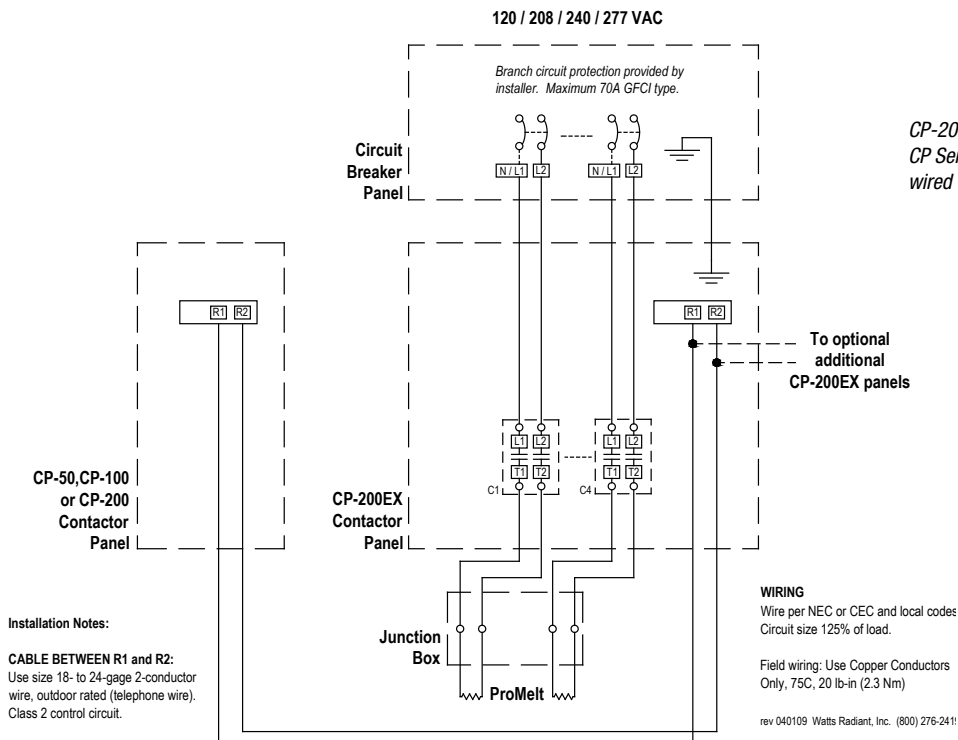

CP-200EX provides an additional 200 amp capacity for any CP Series control. Each CP-200EX contactor needs to be wired directly to a dedicated circuit.

Maximum 100A Heating Load
 120/208/240VAC
 2 circuits
 Slab-mount sense

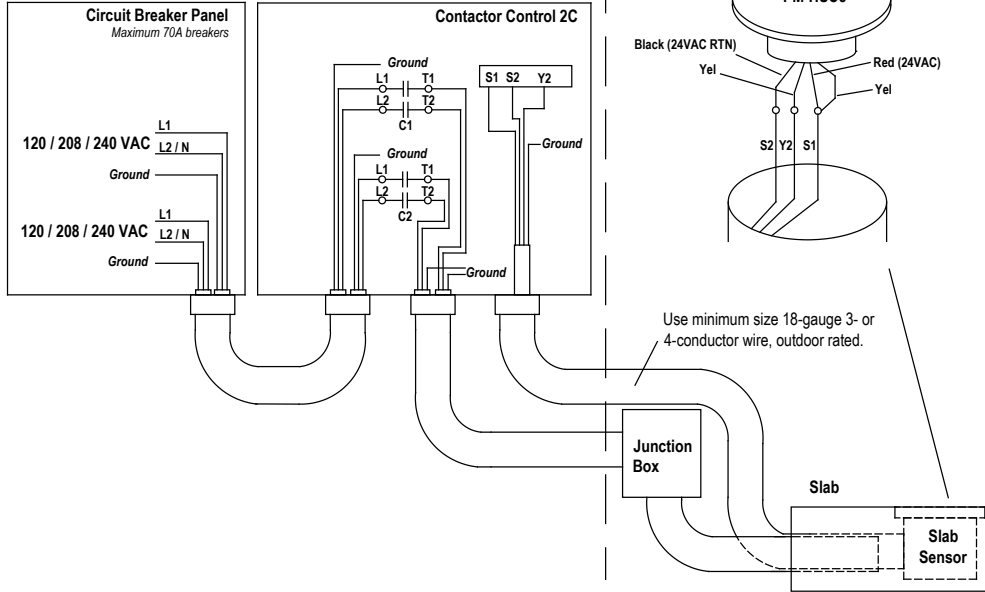

Each ProMelt system can be used with a wide variety of moisture/precipitation sensors, including the following:

Slab Mounted: PM-HSC5
 Pole Mounted: PM-224 and PM-824

Each sensor option is designed to operate a single system. Use a dedicated sensor and CP Control group for each snow melt zone.

Maximum 100A Heating Load
 120/208/240VAC
 2 circuits
 Pole-mount sense

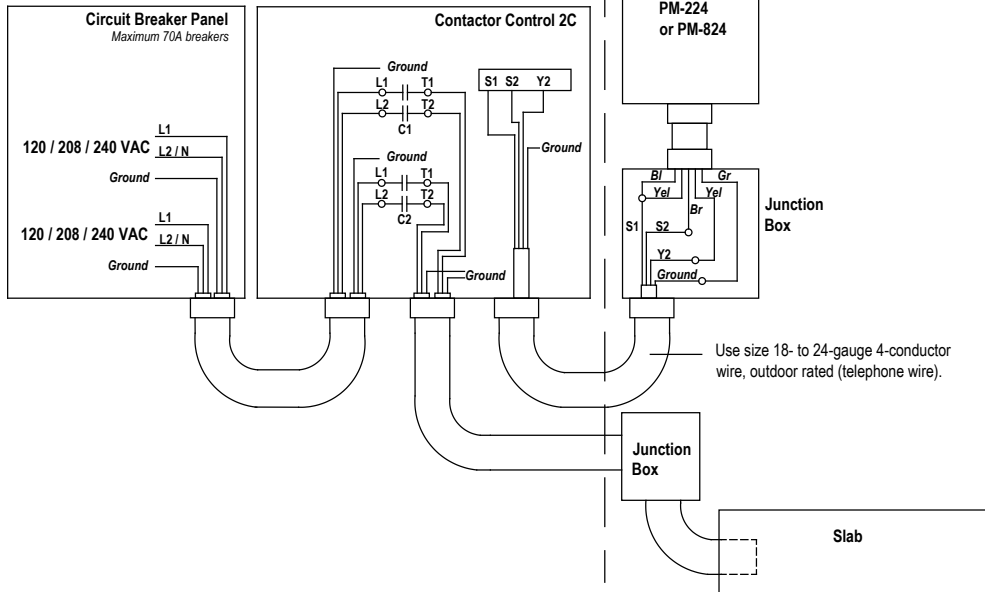

CP-50, CP-100, CP-200 Specifications		
Terminals		Wiring Type
L1, L2 T1, T2	120, 208, 240, 277 VAC	12 AWG (Minimum)
Y1, Y2	Class 2, 24 VAC	18 AWG (Minimum)
R1, R2		
S1, S2		
Compatible Sensors	PM-224 PM-824 PM-HSC5	

CP-200EX Specifications		
Terminals		Wiring Type
L1, L2 T1, T2	120, 208, 240, 277 VAC	12 AWG (Minimum)
R1, R2	Class 2, 24 VAC	18 AWG (Minimum)

⚠ WARNING: General Safety Instructions

- THIS UNIT SHOULD BE INSTALLED ONLY BY QUALIFIED PERSONNEL!**
- Disconnect all power from the control before opening the front cover plate.

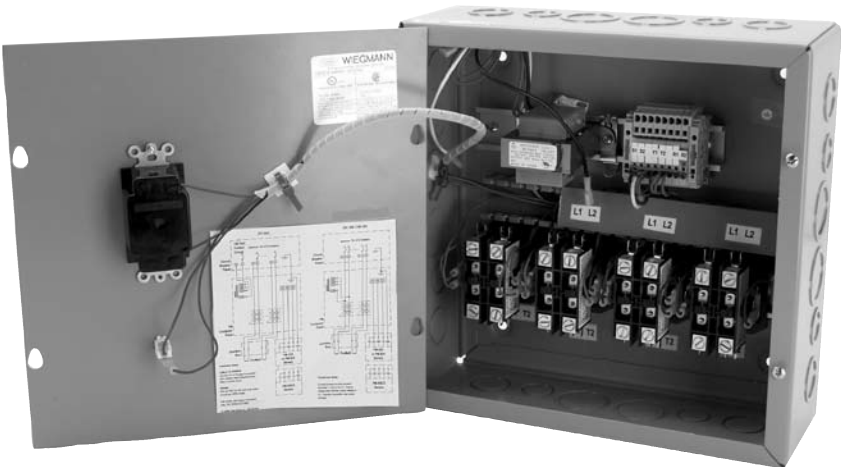

Each CP series control comes pre-wired to the included transformer, terminal blocks, and the coil terminals on the provided contactors. It is not recommended to unwire, or tamper with existing wiring without pre-authorization from the factory.

Limited Warranty: Watts Radiant (the "Company") warrants each product to be free from defects in material and workmanship under normal usage for a period of one year from the date of original shipment. In the event of such defects within the warranty period, the Company will, at its option, replace or recondition the product without charge.

THE WARRANTY SET FORTH HEREIN IS GIVEN EXPRESSLY AND IS THE ONLY WARRANTY GIVEN BY THE COMPANY WITH RESPECT TO THE PRODUCT. THE COMPANY MAKES NO OTHER WARRANTIES, EXPRESS OR IMPLIED. THE COMPANY HEREBY SPECIFICALLY DISCLAIMS ALL OTHER WARRANTIES, EXPRESS OR IMPLIED, INCLUDING BUT NOT LIMITED TO THE IMPLIED WARRANTIES OF MERCHANTABILITY AND FITNESS FOR A PARTICULAR PURPOSE.

The remedy described in the first paragraph of this warranty shall constitute the sole and exclusive remedy for breach of warranty, and the Company shall not be responsible for any incidental, special or consequential damages, including without limitation, lost profits or the cost of repairing or replacing other property which is damaged if this product does not work properly, other costs resulting from labor charges, delays, vandalism, negligence, fouling caused by foreign material, damage from adverse water conditions, chemical, or any other circumstances over which the Company has no control. This warranty shall be invalidated by any abuse, misuse, misapplication, improper installation or improper maintenance or alteration of the product.

Some States do not allow limitations on how long an implied warranty lasts, and some States do not allow the exclusion or limitation of incidental or consequential damages. Therefore the above limitations may not apply to you. This Limited Warranty gives you specific legal rights, and you may have other rights that vary from State to State. You should consult applicable state laws to determine your rights. **SO FAR AS IS CONSISTENT WITH APPLICABLE STATE LAW, ANY IMPLIED WARRANTIES THAT MAY NOT BE DISCLAIMED, INCLUDING THE IMPLIED WARRANTIES OF MERCHANTABILITY AND FITNESS FOR A PARTICULAR PURPOSE, ARE LIMITED IN DURATION TO ONE YEAR FROM THE DATE OF ORIGINAL SHIPMENT.**